

1 - Brook two speed motor, frame 80b, 1, 500 and 3, 000 rpm, T. E. F. C. .9/1.1HP, foot mounted.

1 - Chilton rotary switch ref. C16. 8AF443E with R. G. 001 black handle.

Voltage 380/420/3 phase 50 cycles 7.5HP/1.1/0.9HP D. O. L.

1 - MTE UCO unit, pack 1 size 5

1 - " " " " 2 " 5

1 - " " " " 3 " 10

2 - " Overload units Vol 1/2

1 set - MTE Heater elements 7.5 amps 95 000 556 006

1 set - " " " 2.2 amps 95 000 555 002

Voltage 340/380 3 phase, 50 cycles 380/420 3 phase, 50 cycles 7.5HP/1.1/0.9HP

Star Delta

3 - MTE UCO Units pack 1 size 5

3 - " " " " 2 " 5

3 - " " " " 3 " 10

1 - " " " " 4 " 5

1 - " " " " 5 " 5

1 - " " " " 7 " 10

2 - " Overload units Vol 1/2

1 set - MTE Heater elements 5 amps 95 000 556 004

1 set - " " " 2.2 amps 95 000 555 002

Special for 60 cycle machine

Sprocket Pulleys and Chains

2 - 38 tooth cast iron feed roller sprocket, 1 $\frac{1}{4}$ " bore, B-1002/108

1 - 38 tooth cast iron rise and fall sprocket 1" bore B-1002/108

1 - 36/17 tooth cast iron gearbox and feed sprocket B-1045/171

1 - 19 tooth cast iron jockey sprocket B-1031/59

1 - 25 tooth cast iron clutch sprocket B-1045/5

1 - 19 tooth cast iron R & F sprocket B-1045/49

1 - 13 tooth idler sprocket 7/8" bore A-1033/233

1 - Cutterblock pulley B-1045/145

1 - Cutterblock motor pulley B-1045/146

1 - Variable feed pulley, picador 5" dia autojust pulley Fig. 98

1 - Feed gearbox pulley, picador 6" dia pulley Fig. 1A 5/8" bore and keyway

1 - Feed motor pulley (2 step drive) B-1045/15 (Special)

1 - Feed gearbox pulley (2 step drive) B-1045/14 (Special)

1 - Renolds chain cat No. 110046

Feed roller drive - 87 links including joining link

Table hand R & F - 32 links including joining link

Table power R & F - 29 links including joining link

Special 60 cycle electrics

1 - Brook 7 $\frac{1}{2}$ HP motor, frame kompact L213TD, 3, 600 rpm T. E. F. C. flanged mounted no spigot, 3 phase

1 - Brook two speed feed motor, frame 80B, 1, 800 and 3, 600 rpm T. E. F. C. .9/1.1 HP foot mounted

Voltage 550/3phase 60 cycles 7.5HP/1.1/0.9HP

2 - MTE UCO Units, pack 1 size 5

2 - " " " " 2 " 5

2 - " " " " 3 " 10

2 - " Overload units Vol 1/2

1 set - MTE Heater elements 7.5 amps 95 000 556 006

1 set - " " " 1.5 amps 95 000 556 007

24 ROLLER FEED PLANER

& THICKNESSER

TYPE BAO

Handwheel for height adjustment of under table rollers

Scale for finished thickness of timber being machined.

Push button station

Wackin
BURSCREEN

Lever for varying speed of feed range.

Handwheel for final adjustment of rise and fall of table.

Locking handle for table support column.

Rotary Switch for Power Rise and fall of table and changing speed of feed rollers.

Lever for power rise and fall of table

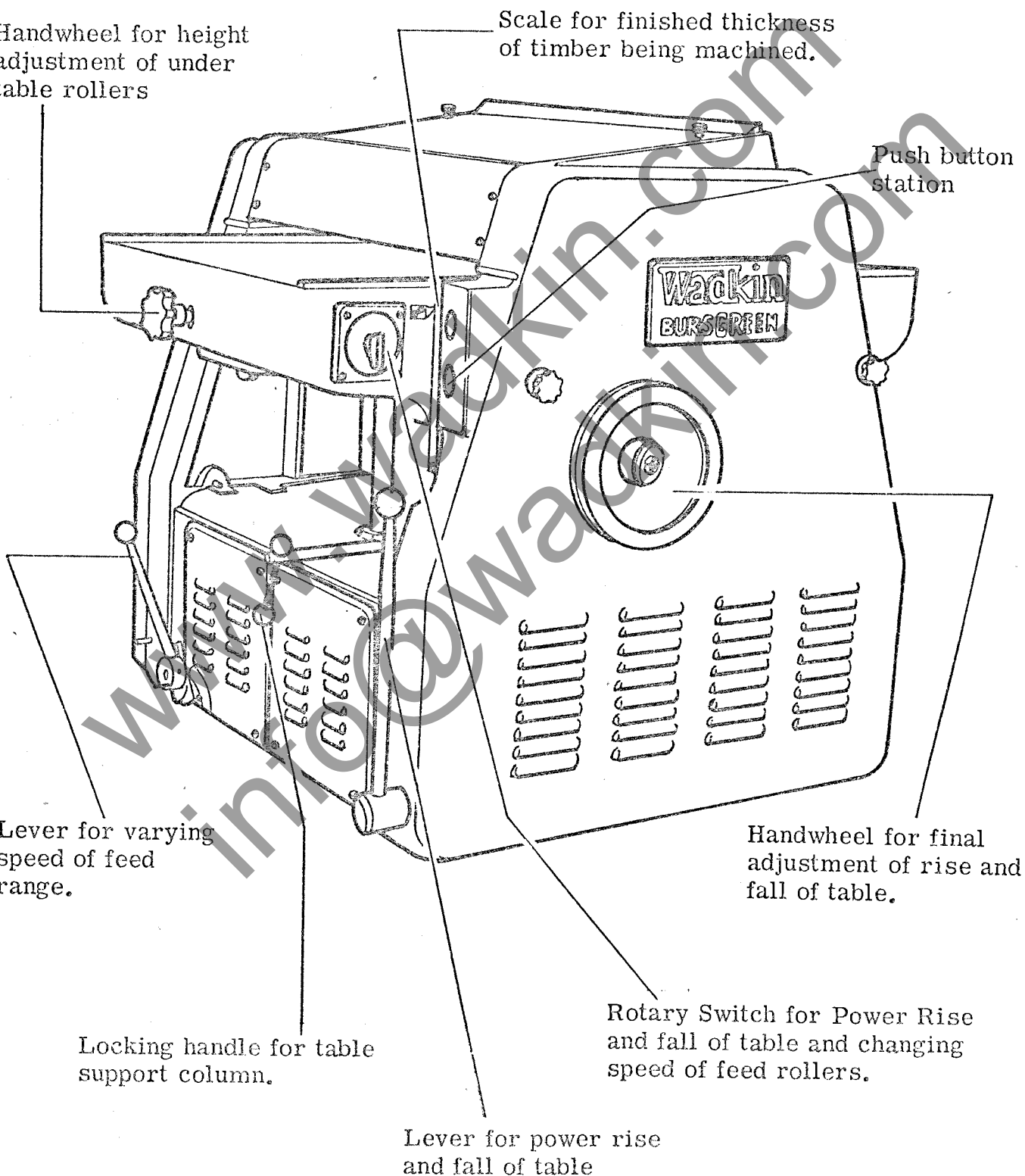

SPECIFICATION

Length of thickening table	44"	1120mm
Feed speeds per minute	20 - 60ft	6-18mm
Speed of motor:- 50 cycles		3,000rpm
60 cycles		3,600rpm
Speed of cutterblock		4,500rpm
Horsepower of cutterblock motor		7½HP
Approx. Floor Space	46" x 43"	1170 x1100mm
Approx. Net Weight	2160 lb	980kg
Approx. Gross Weight	2350 lb	1066kg
Shipping dimensions	66cu. ft.	1.9m ³

Installation

Remove protective coating from all bright parts by applying a cloth soaked in paraffin, turpentine or other solvent.

Wiring Details

The motor and control gear have been wired in before despatch. All that is required is to connect the power supply to the starter or isolator when fitted.

Points to note when connecting to power supply:-

1. Check that the voltage, phase and frequency correspond to those on the motor plate, also the correct coils and heaters are fitted to the starter.
2. It is important that the correct cable is used to give the correct voltage to the starter as running on low voltage will damage the motor.
3. Check the main line fuses are of the correct capacity. See list below. When an isolator is fitted these are correct as received.
4. Connect the line leads to the appropriate terminals. See fig. 1 for 3 phase supply.
5. Check all connections are sound.
6. Check the rotation of the motor for correct direction. If this is incorrect, reverse any two of the line lead connections.

Voltage	Phase	H. P.	S. W. G, Tinned Copper Wire	Amps
220	3	7½/1	19	23
380/420	3	7½/1	24	12
550	3	7½/1	25	9

Lubrication

It is advisable to keep all bright parts covered with a thin film of oil to prevent rusting. See Fig. 3.

TYPE OF OIL RECOMMENDED

POWER EM 125

TYPE OF OIL RECOMMENDED

(For general purposes)

SHELL VITREA 75

TYPE OF GREASE RECOMMENDED

(For gearbox)

SHELL ALVANIA 3.

Foundation

See Fig. 2 for bolt positions and clearances required.

Foundation bolts are not supplied with the machine except by special order.

HIGH SPEED (FEED DOWN & UP)

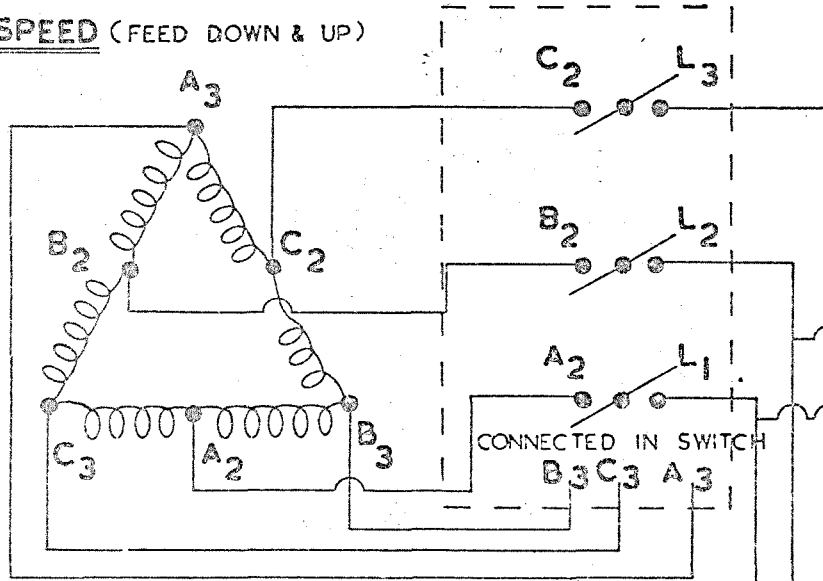

TO REVERSE DIRECTION CHANGE A₂ & B₂

SLOW SPEED (FEED)

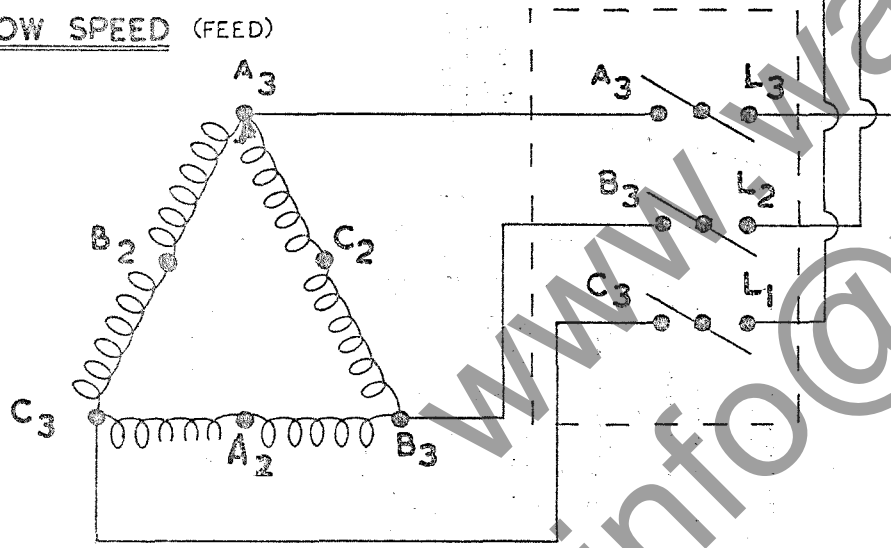

TO REVERSE DIRECTION CHANGE A₃ & B₃

WIRING DIAGRAM

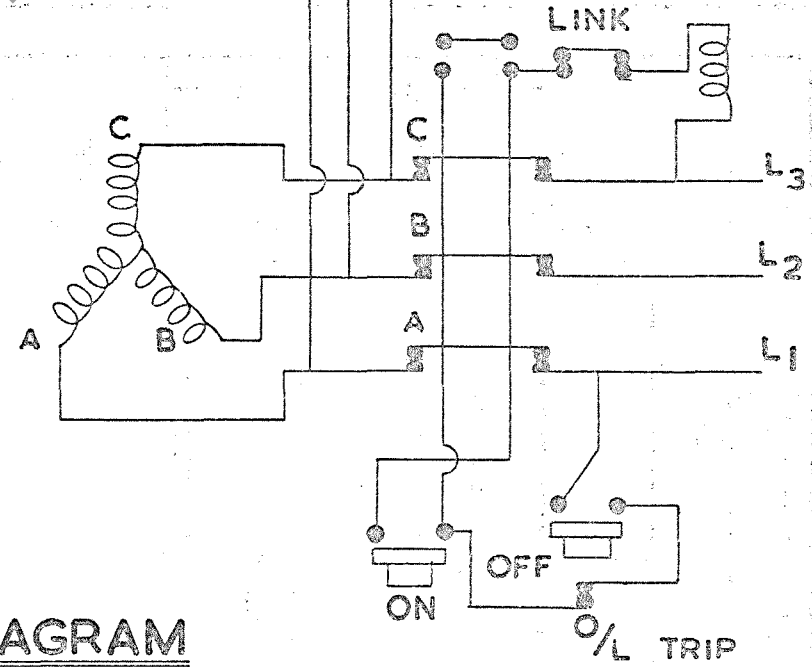

FIG 1.

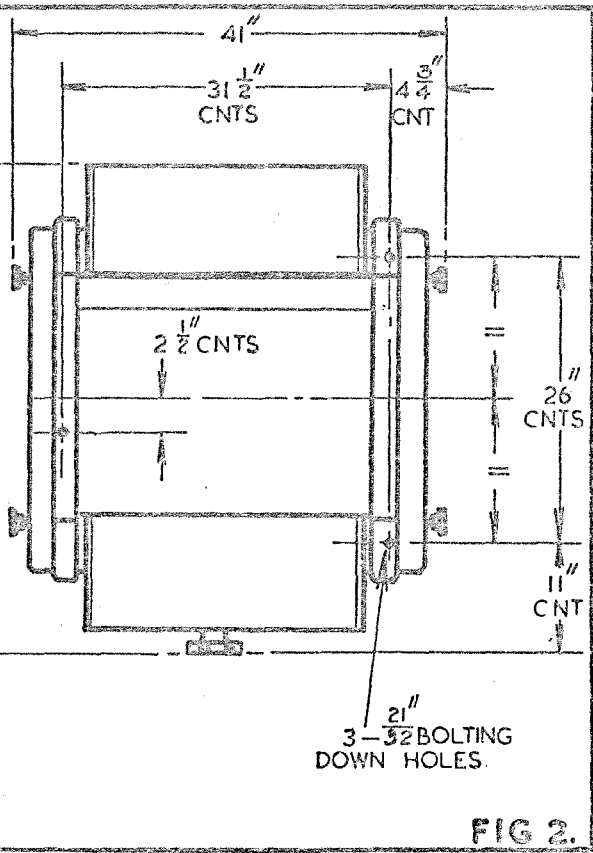

FIG 2.

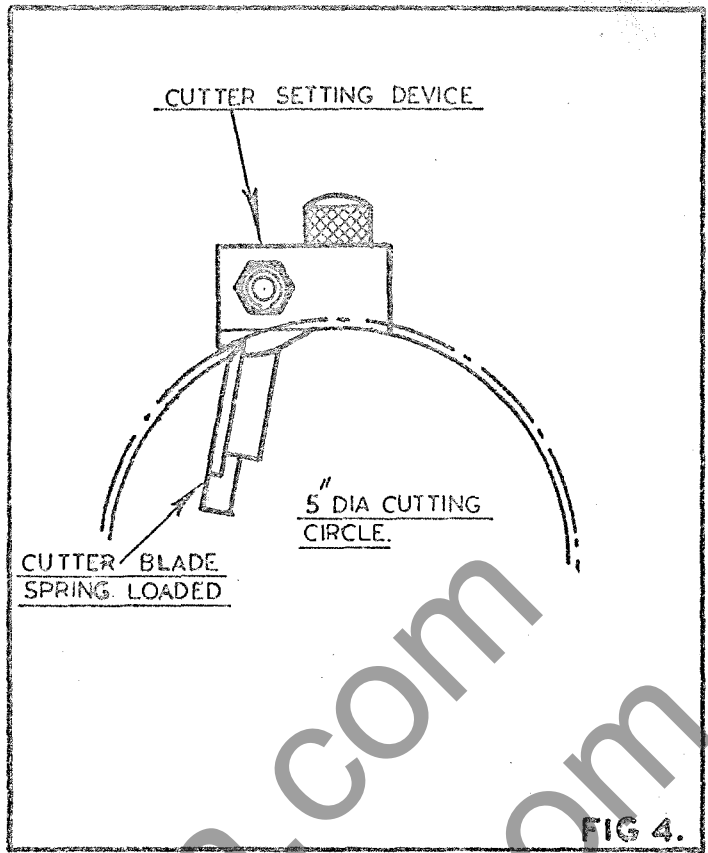

FIG 4.

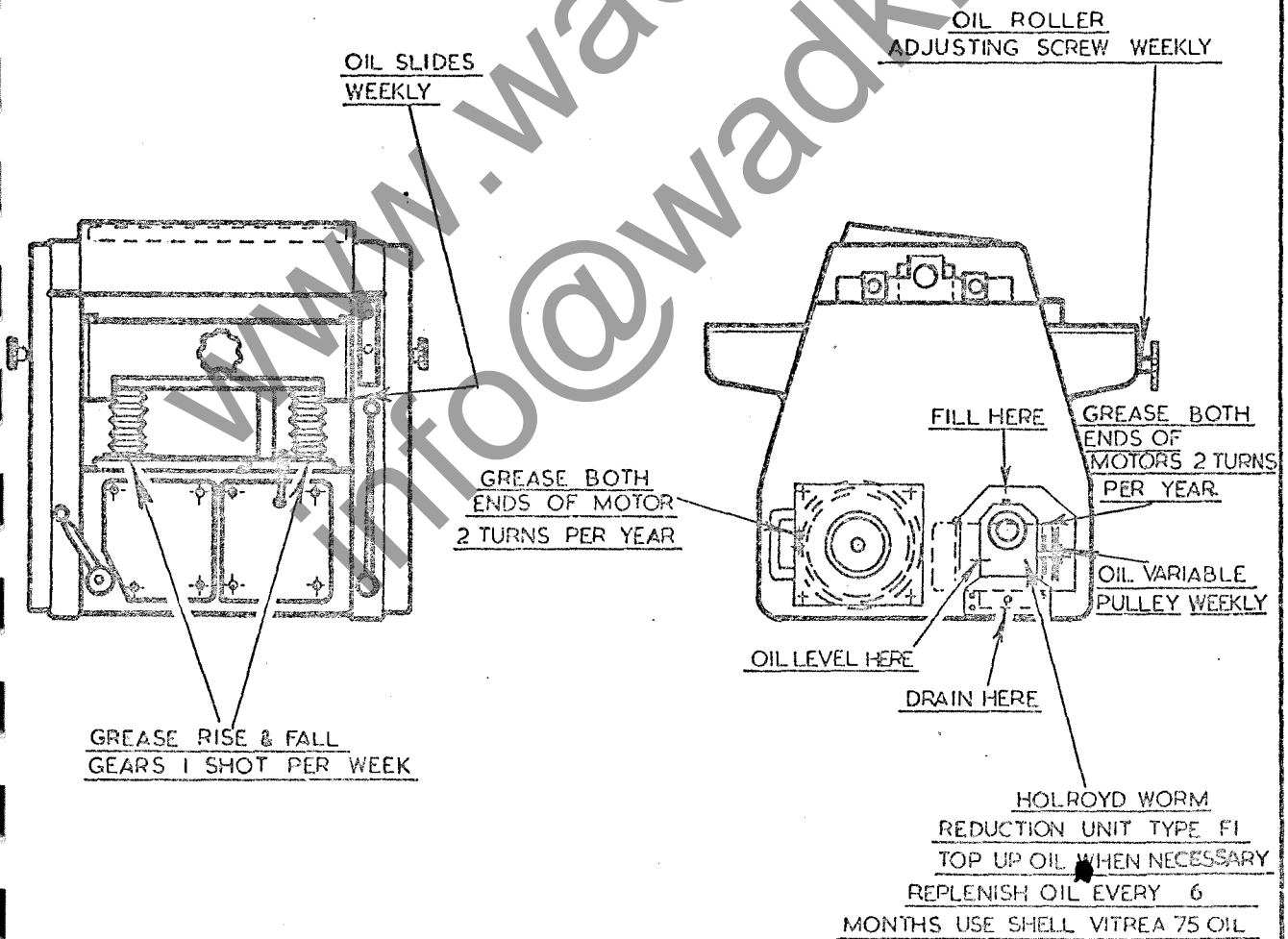

FIG 3.

Belt Tension

The cutterblock drive is by 3 vee belts from a 7½HP motor. To tension the belts, remove the drive side panel and loosen the 4 hexagon head bolts securing the motor mounting plate to the side frame. Move the plate down the slots until the correct tension is reached. When set re-lock the hexagon head bolts.

Replace side panel before operating machine.

Feed Chain Tension

Drive to the feed rollers is by roller chain from a two speed motor and reduction gearbox, giving feed speeds of 20 to 60ft per minute (6-18m per minute.)

It should be noted that the feed chain must run with sufficient slack to allow the front serrated feed roller to freely lift 5/16" (8mm) from the rest position. To adjust, remove drive side panel and loosen the two hexagon nuts securing the jockey sprocket arm to the side frame and adjust until the required tension is reached. Care must be taken to ensure 5/16" (8mm) lift to feed roller. When set re-lock hexagon nuts.

Replace side panel before operating machine.

Thicknessing Table Rise and Fall Controls

The thicknessing table rises and falls on slides and screws controlled through skew gears and chain drive from the conveniently placed handwheel to the right of the thicknessing table. The table is also fitted with power rise and fall which is operated by the lever on the side frame to the right of the table. The table can be locked in any position by the toggle lever under the table.

The finished thickness of the timber is clearly shown on the rule, on the right hand side frame and indicated by a pointer.

Thicknessing table rollers

The anti-friction table rollers or bed rollers revolve on sealed for life ball bearings and require no lubrication. These are adjustable simultaneously by means of the handwheel at the infeed end of the thicknessing table. Turning the handwheel in a clockwise direction increases the height of the rollers above the table surface

In all cases the lowest position consistent with good and regular feeding should be used as this will give the best possible results. Should the table rollers be removed for any reason care must be taken to replace them exactly as before otherwise the settings will be disturbed.

It must be emphasised that a really good surface finish from a thicknessing machine is only possible when the face of the timber resting on the machine table is flat and has a reasonable finish. Wherever practicable this face should be pre-machined on an over-hand jointer or surfacer to remove twist and other irregularities.

Also to assist feeding the under table rollers should be cleaned at regular intervals or resin, etc which tends to build up and thus create an eccentric rolling action to the rollers which in turn give inaccurate and jerky feeding to the timber.

Adjusting bed rollers

It is most important that the bed rollers are parallel to the thicknessing table at all times to ensure good feeding. Should the bed rollers be disturbed for any reason and are incorrectly aligned to the thicknessing table the undermentioned procedure should be followed.

1. Clear thicknessing table of all chippings etc and place a straight edge over both rollers to one side of the table.
2. Check the straight edge is parallel throughout the length of the table, also check the bed rollers are parallel across the width of the table.

3. To adjust the height of the bed rollers raise thickening table to approximately the top position and adjust the 4-3/8" whit hexagon head bolts and nuts on the underside of the thickening table directly below each end of the bed rollers.

When bed rollers are correctly set ensure all bolts are securely locked in position.

Feed Roller & Pressure Bar Settings

These are pre-set at the works in accordance with the details given in Fig. 5. and vertical adjustment relative to the cutterblock is neither possible nor necessary provided the cutters are correctly set with the special gauge supplied with the machine.

Should replacement feed rollers or pressure bars be fitted at any time the settings should be very carefully checked with those given in Fig. 5.

Some slight advantage in finish or feed on occasions can be obtained by increasing or decreasing the tension of the pressure bar or feed roller springs.

The springs should never be compressed to a point where the feed rollers and pressure bar cannot lift sufficient to allow the maximum cut to be taken.

Feed Drive Control

The drive between the 1 horsepower two speed motor and reduction gearbox is by vee belt and variable pulley to obtain the feed speeds of 20 to 60ft per minute (6-18 m. per minute.) The speed of the motor is selected by the rotary switch which is positioned on the right hand side of the thickening table. This also determines the direction of the power drive to the table. The motor is movable on a pivot by means of the lever on the left hand side frame. It should be noted that the machine should be run through the range of feed speeds daily to ensure the variable pulley is working efficiently.

Cutter Setting

The cutters are held in the cutterblock by a steel clamping bar secured with 9 - 1/2" whit heat treated socket head screws. When the locking screws are released the cutter is ejected slightly by small leaf springs. This is to facilitate easy setting with the special gauge supplied. This sets the cutters to 5" (127mm) cutting circle diameter and should any other method of cutter setting be employed the amount of cutter projection must correspond to that given by the setting gauge supplied.

Note:-

It is most important that the hexagon socket in the knife locking screws is kept clear of all gum and dirt to ensure easy removal of screws when changing knives.

Always ensure that the hexagon key is fully inserted in the screw when locking or unlocking the cutters. This avoids damage to the hexagon sockets.

Periodically examine screws for damage or cracks particularly in the hexagon hole. Any doubtful screws should be replaced and all screws well lubricated with "Molyslip" or similar oil, before replacing.

To remove cutters and re-set with the "Bursgreen" cutter setting gauge proceed as follows:-

1. Lift the cutter guard clear of the cutterblock and swing to the rear of machine.
2. Turn cutterblock to a position suitable for access to securing screws. Slacken the securing screws until the knife is just free of the cutterblock. Care should be taken when loosening the last screw as the knives are spring loaded.
3. To re-set the knives. Place the knife in the slot making sure that all faces are clean and the clamping bar free from burrs. Press the knife into the cutterblock and lock the setting device to the cutterblock body with the knurled headed screws supplied until the predominant pads rest on the cutterblock body as shown in Fig. 4. Position the knife central in the cutterblock.

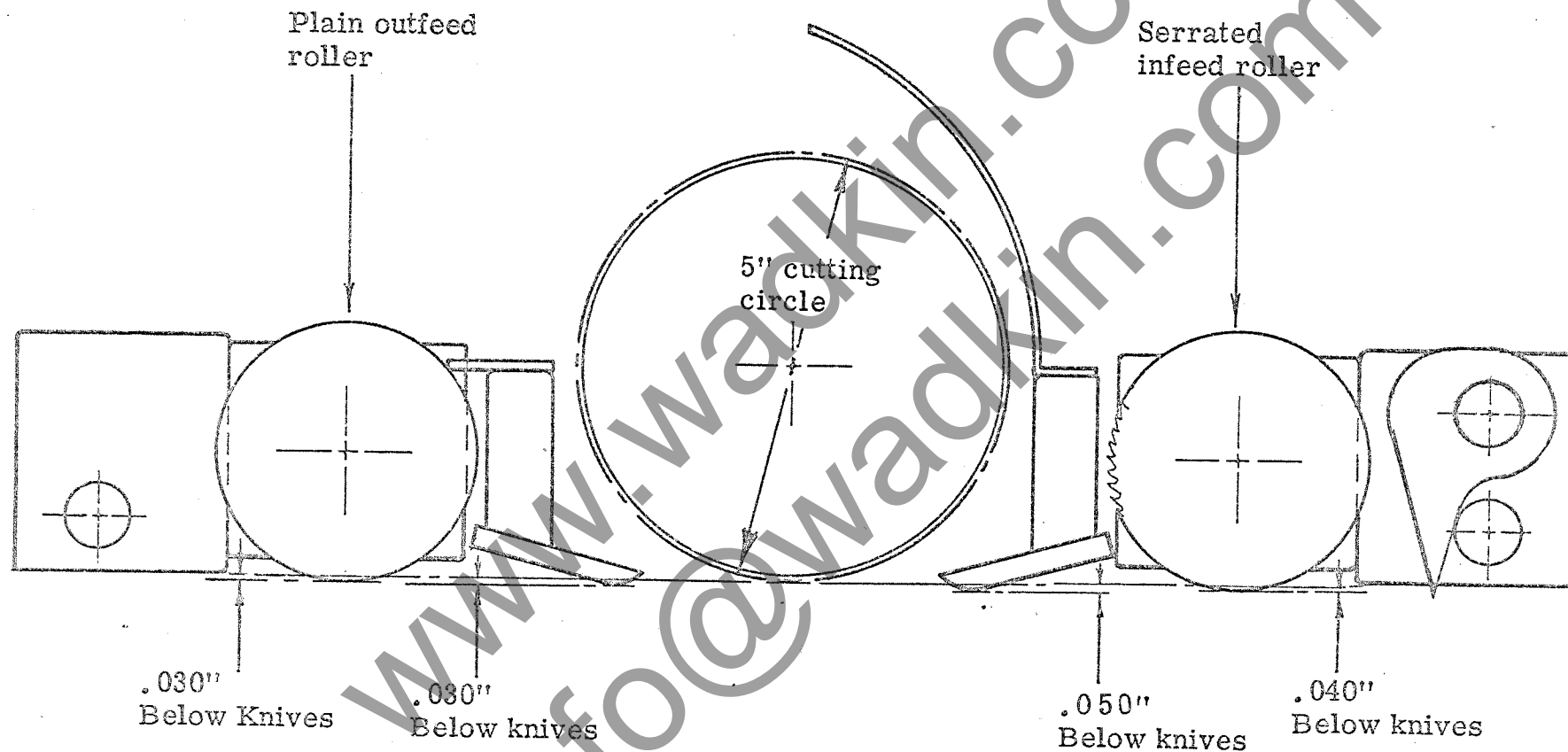

FEED ROLLER & PRESSURE BAR SETTINGS

4. Tighten the securing screws. The cutting edge will now be parallel to the cutter-block body and the thickening table.
Check all securing screws have been fully tightened before proceeding to set the rest of the knives.

General Hints

1. When thickening long lengths of timber always support after the machine table, otherwise a step will appear on either or both ends.
2. When a smooth finish is required use a slow feed speed. For roughing when the finish is not important use a fast feed speed.
3. For the best results always feed the timber to cut with the grain.
4. Should the timber stick when thickening probable causes are given below:-
 - a) The table rollers are set too low in table.
 - b) The spring pressure is too great on the pressure bars and too light on the feed rollers
 - c) The timber is too roughly sawn or badly twisted and requires pre-facing.
 - d) The timber may be tapered in its length and thus wedged under the cross tie bar.

SPARES LIST FOR 24" BAO

- 1 pair HSS planing cutters 24 $\frac{1}{2}$ " long x 1 $\frac{1}{2}$ " wide x 1/8" thick
- 1 - Cutter setting device
- 1 - Clutch control cable B-1020/11
- 2 - Table R & F clutch discs A-1045/109

Bearings Used

- Cutterblock bearings :- 3 - Fischer 6208FF sealed for life bearings
- Table R & F assembly :- 2 - SKF 010 Thrust races
2 - SKF 08 Thrust races
- Under Table Rollers :- 4 - SKF 6203 2RS sealed for life bearings
- 3 - Fenner's alpha 670 spacesaver vee belts cutterblock drive
- 1 - Fenner's A30 vee belt variable feed drive
- 1 - Fenner's alpha 280 spacesaver vee belt, 2 step feed drive

Sprockets Pulleys and Chain for 50 cycle machine

- 1 - 25 tooth cast iron clutch sprocket B-1045/5
- 1 - 19 tooth cast iron rise and fall sprocket B-1045/49
- 1 - 13 tooth idler sprocket, 7/8" bore A-1033/233
- 2 - 38 tooth cast iron feed roller sprocket 1 $\frac{1}{4}$ " bore A-1002/102
- 1 - 38 tooth cast iron R & F sprocket 1" bore A-1002/108
- 1 - 19 tooth cast iron jockey sprocket 7/8" bore A-1031/59
- 1 - 38/19 tooth cast iron gearbox and feed sprocket B-1045/22
- 1 - Cutterblock pulley B-1045/24
- 1 - Cutterblock motor pulley B-1045/25
- 1 - Variable feed pulley, Picador 5" dia autojust pulley Fig. 98
- 1 - Feed gearbox pulley, Picador 6" dia pulley Fig 1A 5/8" bore and keyway
- 1 - Feed motor pulley (2 step drive) B-1045/15 (Special)
- 1 - Feed gearbox pulley (2 step drive) B-1045/14 (Special)
- 1 - Renolds chain, cat No.110046
- Feed roller drive - 39 links including joining link
- Table hand R & F - 32 links including joining link
- Table power R & F - 29 links including joining link

50 cycle electrics

- 1 - Brook 7 $\frac{1}{2}$ HP motor, frame D. 213, 3000 rpm, T.E.F.C. flange mounted no spigot, star delta wound, 3 phase

Voltage 208/220/3 phase 60 cycles 7.5HP/1.1/0.9HP

- 1 - MTE UCO Units pack 1 size 5
- 1 - " " " " 2 " 5
- 1 - " " " " 3 " 5B
- 1 - " " " " 1 " 20
- 1 - " " " " 2 " 20
- 1 - " " " " 3 " 20
- 1 - " " " " 8 " 203
- 2 - " Overload units Vol 1/2
- 1 set - MTE Heater elements 16.5 amps 95 000 558 000
- 1 set - " " " 3.3 amps 95 000 556 003

www.wadkin.com
info@wadkin.com